



AV-DT Series

Duct Air Velocity Transmitter



Overview

The AV-DT series of air velocity transmitters is engineered for building automation in the HVAC/R industry. The AV-DT measures air velocity and temperature, with field selectable ranges and output options in a single device.

Designed with a duct mount probe and adjustable collar suitable for round or rectangular ducts. Options include a relay, and a backlit LCD available in Metric or Imperial measurements.

Applications

- Used to measure, regulate and/or monitor airflow speed via PLC / outstation / EMS

Features & Benefits

- Converts airspeed into 4-20mA or 0-10Vdc output signal
- Optional Display option
- Available in Metric or Imperial (w/ Display)
- Optional Relay Output
- Selectable airflow ranges

Model Selection

AV-DTXX	Duct Air Velocity Transmitter, No Display, no Relay
AV-DTMX	Duct Air Velocity Transmitter, with Display, Metric, no Relay
AV-DTIX	Duct Air Velocity Transmitter, with Display, Imperial, no Relay
AV-DTMR	Duct Air Velocity Transmitter, with Display, Metric, with Relay
AV-DTIR	Duct Air Velocity Transmitter, with Display, Imperial, with Relay

Product Specifications

Velocity Ranges	Base & Metric Models: 0-2, 10 & 20m/s, field selectable Imperial Model: 0-400, 2000 & 4000 fpm, field selectable
Velocity Accuracy	Metric: Range - 0...2 m/s: <0.2 m/s + 5% from reading Range - 0...10 m/s: <0.5 m/s + 5% from reading Range - 0...20 m/s: <1.0 m/s + 5% from reading Imperial: Range - 0...400 fpm: <20 fpm + 5% from reading Range - 0...2000 fpm: <100 fpm + 5% from reading Range - 0...4000 fpm: <200 fpm + 5% from reading
Thermal Shift	±0.8 %FS / °C
Calibration	Units calibrated at 22°C (71.6°F). Rapid thermal shift stabilization time 10 min.
Temperature Range	0 to 50°C (32 to 122°F)
Temperature Accuracy	<0.5°C for velocity >0.5 m/s (<0.9°F for v > 100 fpm)
Operating Conditions	0 to 50°C (32 to 122°F), 0 to 95 %RH, non-condensing
Storage Conditions	-20 to 70°C (-4 to 158°F)
Media Compatibility	Dry air or non-aggressive gases
Output Signal 1 (TOUT)	0-10 Vdc (linear to temperature) L min 1K Ω 4-20 mA (linear to temperature) L max 400 Ω
Output Signal 2 (VOUT)	0-10 Vdc (linear to m/s) L min 1K Ω 4-20 mA (linear to m/s) L max 400 Ω
Optional Relay Output	Potential free SPDT (NC, COM, NO) 250 Vac, 6A / 30 Vdc, 6A adjustable switching point and hysteresis
Power Supply	24 Vdc / 24 Vac ±10%
Current Consumption	Current: 75 mA (90 mA with relay) Voltage: 35 mA (50 mA with relay)
Optional Display	4 digit backlit display Size: 45.7mm W x 12.7mm H (1.79" x 0.5")
Display Units	Metric: m/s and °C Imperial: fpm and °F Alternating Velocity/Temperature in 5 second intervals
Enclosure	Case: ABS Cover: Polycarbonate Ratings: IP54 (NEMA 3) Probe: 304 series stainless steel Mounting Flange: LLPDP
Dimensions	Case: 90mm W x 71.5mm H x 36mm D (3.5" x 2.8" x 1.4") Probe: OD 10mm (0.394"), length 210mm (8.26") from bottom of cover
Mounting	Mounting Flange: Ø4mm (11/64") Adjustable 50 to 180mm (2" to 7.08")
Insertion with flange	
Electrical Connections	Power Supply & Signal Out: 4-screw terminal block 12-24 AWG (0.2 to 1.5mm ²) Relay Out: 3-screw terminal block 12-24 AWG (0.2 to 1.5mm ²)
Cable Entry	M16 (0.625") cable gland
Weight	220g (7.76oz)
Approvals	CE, RoHS
Country of Origin	Finland



Wiring Information

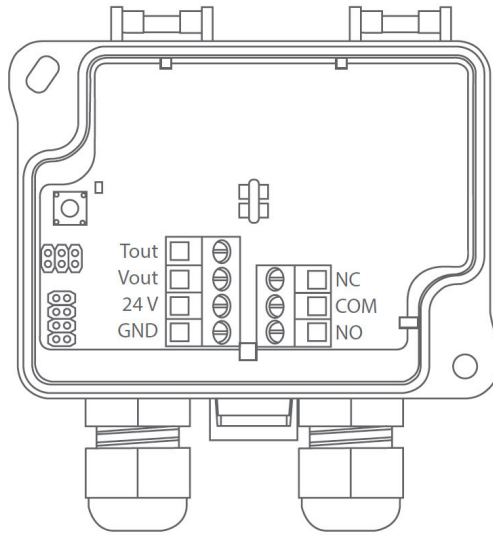

TERMINAL	FUNCTION
Tout	Analog Output
Vout	Analog Output
24 V	Power Supply
GND	Common
NC	Digital Output
COM	Common
NO	Digital Output

Dimensions

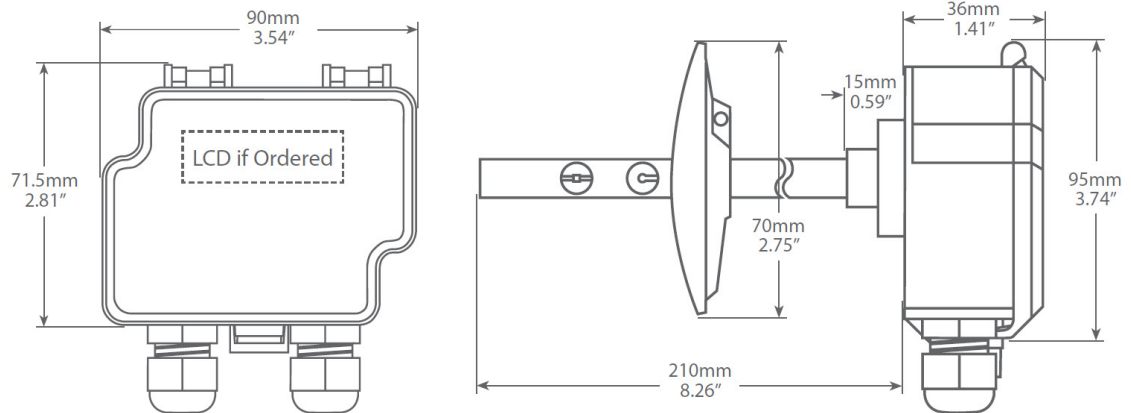

Specifications subject to change without notice.
 Distech Controls, and the Distech Controls logo are trademarks of Distech Controls Inc. All other trademarks are property of their respective owner.
 ©, Distech Controls Inc., 2020. All rights reserved.